

# BOWS to Bring

By Sam Brown

Hunting game with bow and arrow packs a real wallop. There's a thrill in seeing an arrow go winging toward its mark. Even a close miss is fun. So many sportsmen have adopted this sport that some states have exclusive bow-and-arrow hunting reserves where firearms are prohibited.

A bow for hunting should be as short as practical, ranging in length from 4 ft. 8 in. to 5 ft. 6 in. It should be a plain bow, able to stand a lot of knocking around.

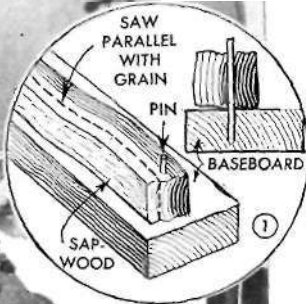
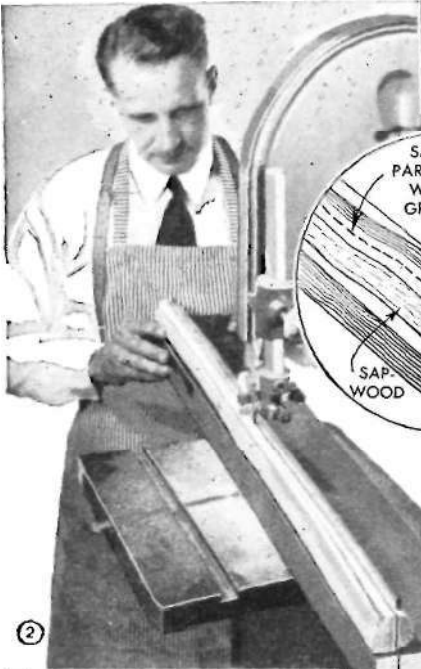

NET SIZES FOR 40 TO 50-LB. BOWS

WOOD	T	W	SAP
OSAGE	1 1/16"	1 3/16"	3/16"
ORANGE	3/4"	1 7/16"	3/4"
YEW	3/4"	1 7/16"	3/4"
BOAM	3/4"	1 1/2"	3/16"
LEMON-WOOD	1 1/16"	1 3/4"	NONE

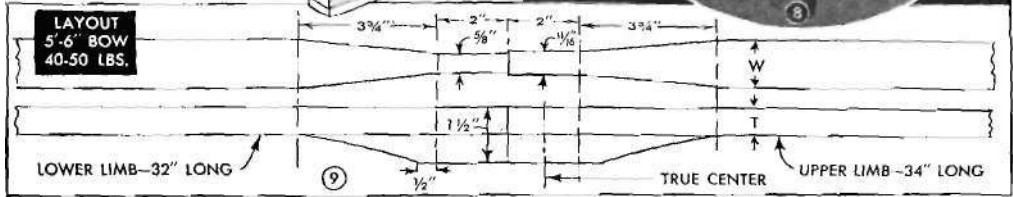
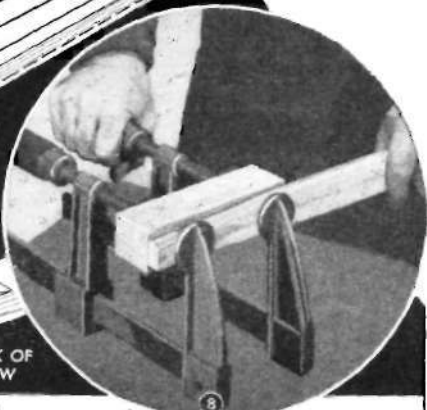
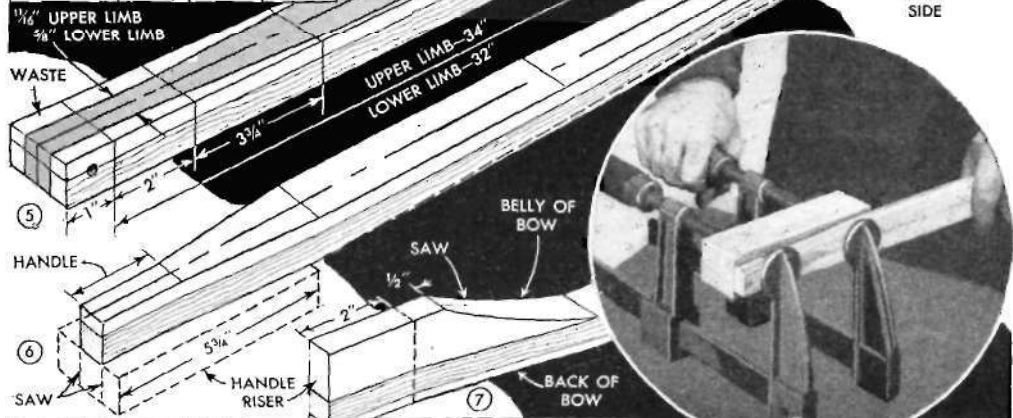

# 'em Down

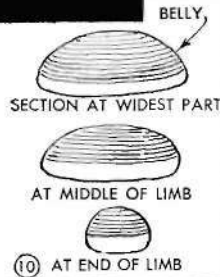

The drawing weight need not be excessive; you can bring down the toughest game in the country, including moose, bear and wild boar, with a 45 to 50-lb. bow and a steel broadhead arrow. Most hunters prefer a flat or semiflat bow. The demountable type of semiflat bow described here is popular because of ease of transportation, and the knockdown handle in no way affects smooth, fast shooting. If this is your first bow, by all means make it of lemonwood, as this compact and nearly grainless wood permits mechanical shaping without any regard to grain structure. If you want the best, however, use osage orange or boam. Yew is good, too, although a little too soft for rough usage. All bow woods except lemonwood require careful following of the grain.

Start by roughing out the back of the bow. Osage orange is perfect in this respect; just peel off the bark, and the remaining layer of sapwood, about *Via* in. thick, is just right. Yew and boam have more sapwood and will require trimming down. This can be done best on a band saw as in Figs. 1 and 2, mounting the stave on a guide board and then saw-

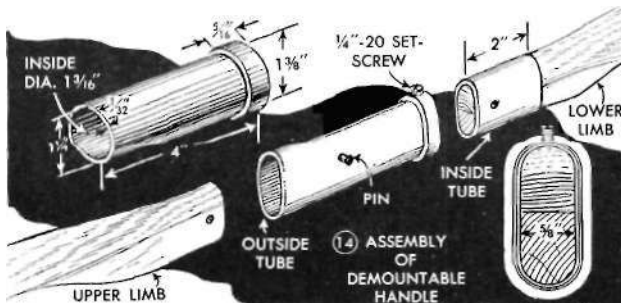
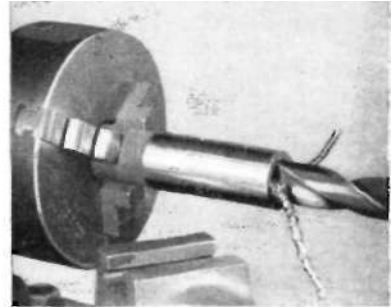

THE HUNTING BOW should be as short as practical, with pulling weight of 40-60 lbs. Style shown is semi-flat, with demountable handle for ease in transportation

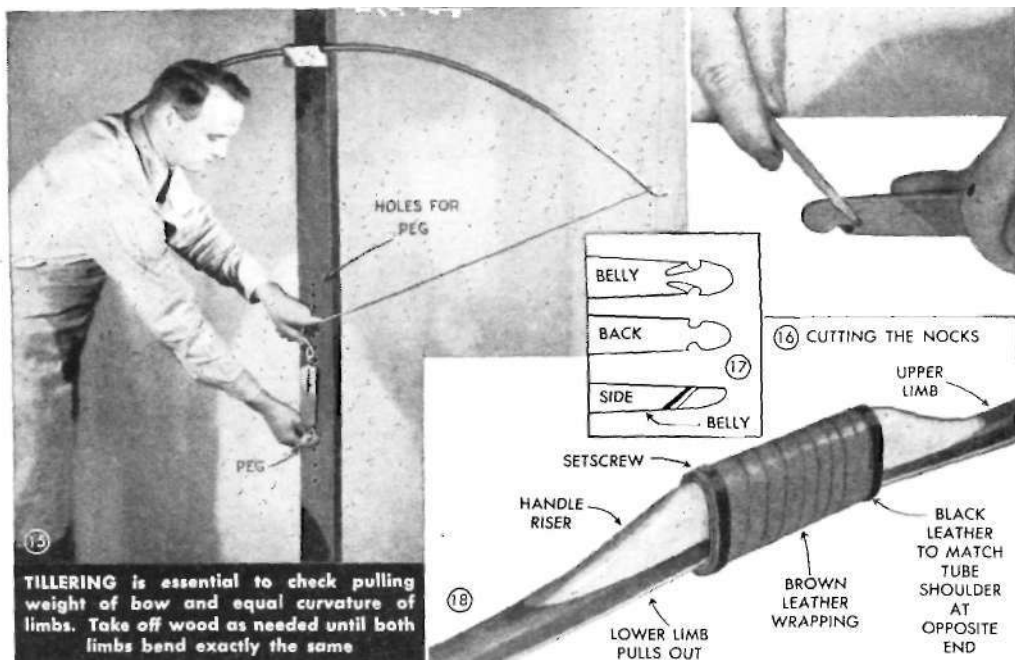

ing on a line the required distance away from the heartwood. Pins holding the stave should be a snug drive fit in holes drilled squarely across the chord of the grain, as indicated in Fig. 1. If there is too much heartwood, it can be trimmed down with the same setup. Where there is just a little extra wood on the heart side, a planer head in the drill press will remove it in a jiffy, Fig. 3. In the absence of power tools, the staves can be trimmed with a drawknife. The first stage of cutting gives you a flat stick about  $\frac{1}{2}$  by  $1\frac{1}{2}$  in. with a thin layer of white sapwood on the back as shown in Fig. 5. Here you can see why it is easy to work with lemon wood; you have no sapwood to worry about, and the compact grain permits ripping and jointing to straight lines. All the other woods will be crooked, the back of the bow following every dip and curve in the grain. After band-sawing, smooth up the back of the bow with drawknife and scraper, following the grain. Fig. 4 shows table of net sizes for bows of different woods.

On the back of the stave, draw the outline shown in Fig. 5, band-saw to shape and taper the belly side as in Fig. 6. You will cut across the grain to some extent in both operations, but it is only on the back of bow that you positively must follow the grain. Glue the handle riser in place, Fig. 8, and then band-saw it both ways to the shape shown in Fig. 7. Both limbs of the bow are treated in the same way except that the upper limb should be 2

in. longer than the lower one, as in Fig. 9.

The demountable feature is accomplished by fitting the limbs of the bow inside a metal tube. You can buy telescoping tubes for this purpose, or you can make your own. Fig. 14 shows the general nature of the assembly. The short inside tube is pinned to the lower limb and the long outer tube is pinned solidly to the upper limb, the lower limb where it is held rigidly by means of a setscrew. Making your own telescoping tube is just a matter of turning and boring, Fig. 12, and then squeezing the assembled tubes in a vise as in Fig. 13, to get the required oval section. It is advisable to heat the work, otherwise the steel may crack at the shoulder portion. The original fit of the round tubes should not be too snug.

Figs. 10 and 11 show the final stage of shaping the bow, rounding off the belly with a drawknife or coarse and fine rasps. Osage orange may be so knotty as to require entire shaping by filing. Whenever you run into a knot, leave a little extra wood to compensate for the natural weakness caused by the defect. Finish off the limbs by scraping with a hook scraper or a piece of broken glass.

As you work down the belly side, tiller the bow frequently as shown in Fig. 15, checking its drawing weight, and more important, the bend of the limbs. Some workers tiller against a wall and use a grid of pencil lines to check for equal bending.

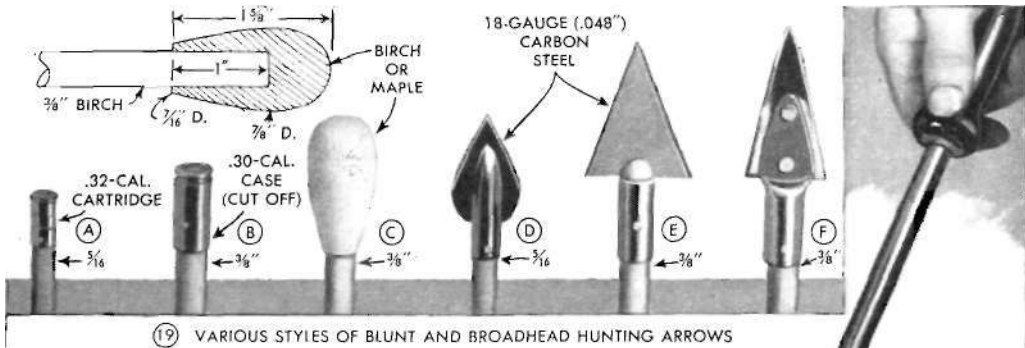

19 VARIOUS STYLES OF BLUNT AND BROADHEAD HUNTING ARROWS

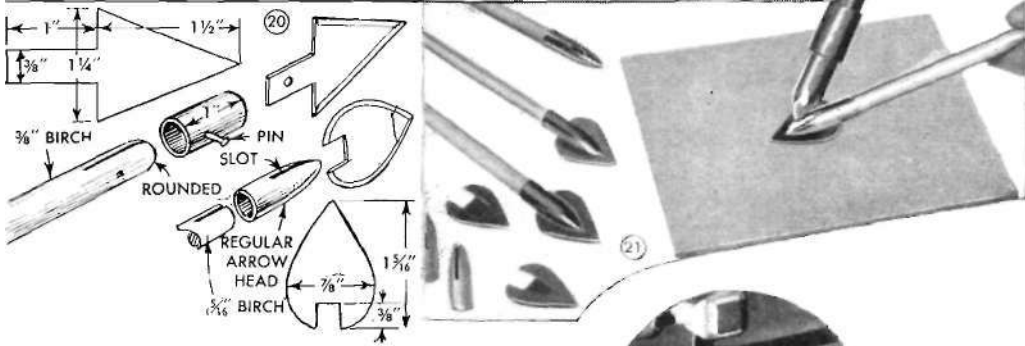

**HUNTING ARROWS** in blunt and broad-head styles are shown on this page. Steel for heads can be obtained from old power-hacksaw blades

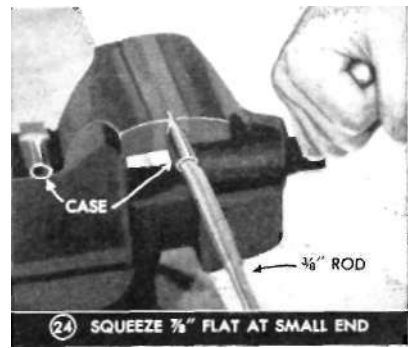
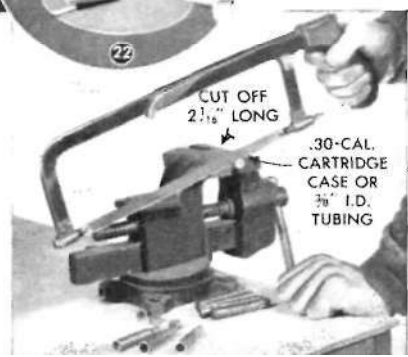
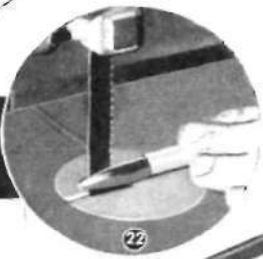

However, good results can be obtained by eye inspection alone, and by noting if the string tends to pull off to one side as you pull it back. The bow should be rigid through the handle, and almost rigid the full length of the handle riser. Starting at the end of the handle riser, the limbs should bend in a graceful arc. Go slow at this stage; it is very easy to remove too much wood and ruin the bow. If you get a little under the poundage you want, cut an inch off both limbs and try it again. Get the pull about 5 lbs. more than you want; it will let down about that much after you have used it a few hours. If the bow is much too heavy throughout, make a fast dip immediately beyond the handle riser to get a thinner section, and then taper gradually to the tips. Nocks should be of the plain type cut into the wood as in Figs. 16 and 17. Fig. 18 shows the finished bow at the handle.

There are two kinds of hunting arrows: blunts and broadheads. The blunt points, details A, B and C of Fig. 19, can be made from cartridge

cases. They will bowl over a rabbit or knock a squirrel out of a tree. The need for the blunt point is obvious; you can imagine what happens to a sharp steel broadhead when you wham it into a tree trunk, or worse, a high tree limb.

Steel broadheads are needed for both small and big game. With sharp-cutting edges, even a 40-lb.

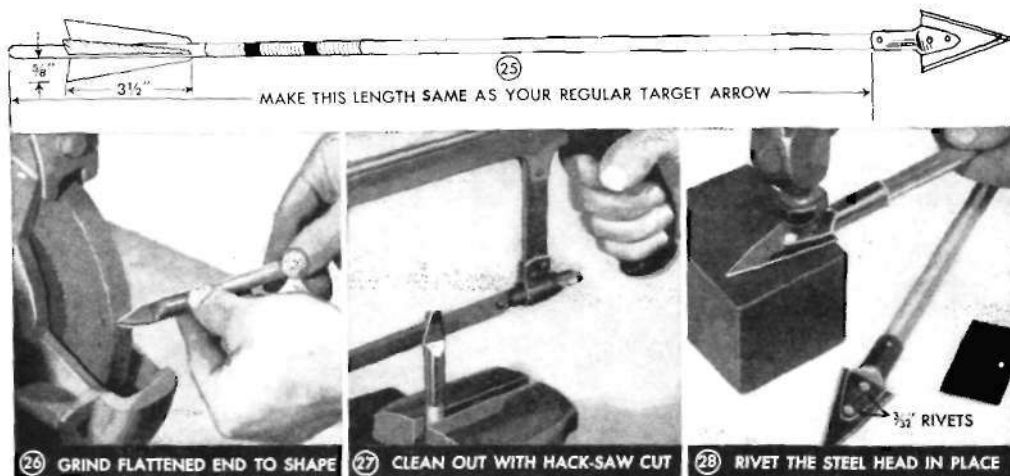

bow will send one of these shafts right through a two-point buck. The smallest practical head is the lancet shown at D, Fig. 19. This is made by slotting a regular bullet-type arrow head, and then soldering the notched steel head into the slot as in Figs. 20, 21 and 22. Easiest type to make in any size of broadhead is the tang-and-sleeve style shown at E and explained in Fig. 20. The step-by-step operation in making a broadhead, style F, is shown in Figs. 23 to 28. If you use .30-cal. ball cartridge cases, it will be necessary to have a tang on the broadhead for needed strength. With a sleeve of thicker copper or steel tubing, the split ends of tube alone will hold the head, which can be made a simple,

triangular shape without tang. Old power hacksaw blades furnish good steel for heads. All of the styles shown can be purchased readymade if desired. Fletching of shafts follows standard practice except that the feathers are preferably of the low, long triangular style as shown in Fig. 25. Complete construction kits including heads, cut feathers and birch shafts can be purchased at a nominal cost and provide an ideal method of working. The diameter of shafts will depend somewhat on the pull of your bow. If the pull is 40 lbs. or under,  $\frac{9}{16}$ -in. or  $\frac{11}{32}$ -in. shafts are plenty heavy. Bows pulling over 45 lbs., especially when big broadheads are used, must have  $\frac{1}{2}$ -in. shafts to stand up under the terrific impact.

## Holes in Window Screen Mended by Easily-Made Patches

Small holes in window screens can be mended by easily-made patches cut from ordinary screen wire, thus making it un-

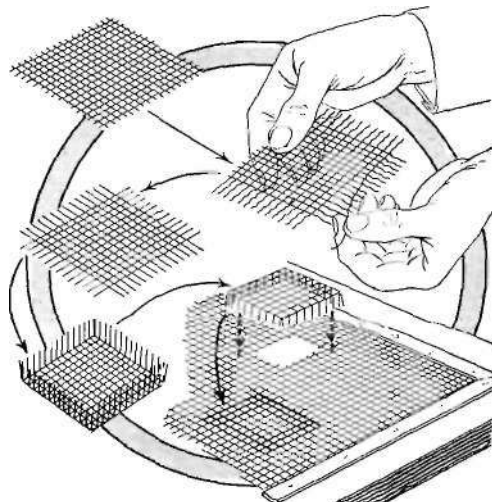

necessary to replace the entire screen. To make a patch, cut a piece of screen a little larger than the hole to be mended. Next, pull two strands from each side of the cut piece, and bend up the projecting wires at a right angle as shown. Place the patch over the hole, push the wire ends through the screen and fold them inward to secure the patch. For a tight seam all around, tap the folds lightly with a hammer, using a block of wood as a support.

H. S. Siegele, Emporia, Kas.

## Sticking of Stamps Avoided When Carried in Pocket

I find that when carrying loose postage stamps in my pocket ox pu™: They will not stick together if I first rub the gummed surfaces lightly over my hair. The thin oil film deposited on the stamps from the hair will last indefinitely and keep the stamps ready for use without interfering with the adhesive.

George K. McKeowan, Painesville, Ohio.